



I cilindri corsa breve, sono stati realizzati per garantire buone prestazioni in spazi molto ridotti. Sono disponibili versioni: doppio effetto e con stelo passante. Sul corpo dei cilindri sono ricavate delle cave dove si alloggiano i sensori.

Ainiv short stroke Cylinders are manufactured to guarantee good performances in very little spaces. There are different version: double acting and through rod. Grooves for auto switch are located on the body, to permit easy handling for adjustment and installation.

CHIAVE DI CODIFICA / KEY TO TYPE NUMBER

CE_00_3_6_000_000

- CORSA / STROKE
- Ø CILINDRO / Ø CYLINDER
- 5=NON MAGNETICO / NO MAGNETIC
6=MEGNETICO / MAGNETIC

VERSIONE - VERSION

- 30=DOPPIO EFFETTO / DOUBLE ACTING
- 31=STELO PASSANTE / THROUGH ROD
- 32 =STELO MASCHIO / MALE ROD
- 34=ANTIROTAZIONE / NO ROTATING
- 35=SEMPLICE EFFETTO MOLLA ANTERIORE / SINGLE ACTING FRONT SPRING
- 36=SEMPLICE EFFETTO MOLLA POSTERIORE / SINGLE ACTING REAR SPRING

VERSIONE - VERSION

30	
31	
32	
34	
35	
36	

CORSE STANDARD - STANDARD STROKES

O16	mm 5-10-25-30-40
O20	mm 5-10-25-30-40-50
O25	mm 5-10-25-30-40-50
O32	mm 5-10-25-30-40-50
O40	mm 5-10-25-30-40-50
O50	mm 5-10-25-30-40-50
O63	mm 5-10-25-30-40-50-75
O80	mm 5-10-25-30-40-50-75-100
O100	mm 5-10-25-30-40-50-75-100

CORSE SEMPLICE EFFETTO - SIMPLE ACTING STROKES

O16	mm 5-10-25
O20	mm 5-10-25
O25	mm 5-10-25
O32	mm 5-10-25-30-40-50
O40	mm 5-10-25-30-40-50
O50	mm 5-10-25-30-40-50
O63	mm 5-10-25-30-40-50

Fluido - Fluid	Aria con o senza lubrificazione - Lubricated or non lubricated air
Temperatura di esercizio - Operating temperature range	-20C° / +80C°
Pressione massima di esercizio - Max operating pressure	10 bar
Forze sviluppate - Force	pag.datì tecnici / technical informations page
Consumo aria - Air consumption	pag.datì tecnici / technical informations page

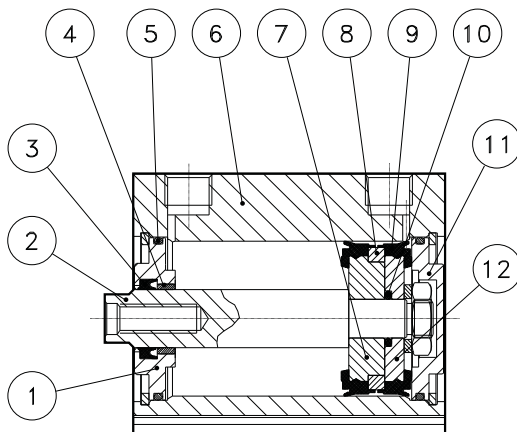

12	FONDELLO PISTONE / BOTTOM PISTON	ALLUMINIO ANODIZZATO / ALUMINIUM ANODIZING
11	TESTATA POSTERIORE / REAR CAP	ALLUMINIO ANODIZZATO / ALUMINIUM ANODIZING
10	O-RING	NBR
9	GUARNIZIONE PISTONE / PISTON SEAL	POLIURETANO / POLYURETHANE
8	MAGNETE / MAGNET	PLASTOFERRITE-NEODIMIO
7	SEMIPISTONE / HALF-PISTON	ALLUMINIO ANODIZZATO / ALUMINIUM ANODIZING
6	TUBO / TUBE	ALLUMINIO ANODIZZATO / ALUMINIUM ANODIZING
5	O-RING	NBR
4	BOCCOLA DI GUIDA / GUIDA BUSH	BRONZO SINTERIZZATO / BRONZE SYNTHERIZE
3	GUARNIZIONE STELO / ROD SEAL	POLIURETANO / POLYURETHANE
2	STELO / ROD	C40 CROMATO / C40 CHROMATE
1	TESTATA ANTERIORE / FRONT CAP	ALLUMINIO ANODIZZATO / ALUMINIUM ANODIZING
Pos.	Denominazione	Materiale

Doppio effetto
Double acting

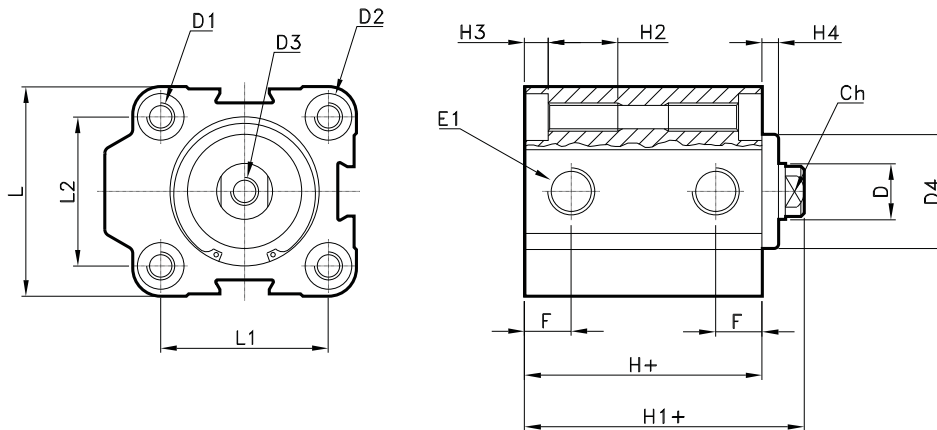
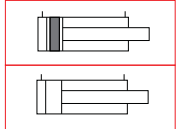

+ = aggiungere la corsa / add the stroke
++ = aggiungere la corsa x 2 / add the stroke x 2

Alesaggio cilindro(mm)	D ø	D1	D2 ø	D3	D4 ø	E1	F	H	H1	H2	H3	H4	L	L1	L2	Ch
16	8	M4	6	M5	-	M5	8	31	35.5	10	3.5	-	28	20	20	7
20	10	M5	7	M5	-	M5	8.5	31	35.5	12	4.5	-	32	22	22	8
25	10	M5	7	M5	-	G1/8"	9	33	38.5	12	4.5	-	38	28	26	8
32	12	M6	10	M6	24.5	G1/8"	10	36	45	15	5.5	3.5	45	36	32	10
40	12	M6	10	M6	30	G1/8"	11.5	41	53	15	5.5	5.5	54.5	40	40	10
50	16	M8	12	M8	35	G1/8"	11.5	42	55	20	6.5	5.5	65	50	50	13
63	16	M10	14	M8	35	G1/8"	12	42	57	25	9	6.5	80	62	62	13
80	25	M10	14	M10	44	G1/4"	14	52	70	25	9	10	100	82	82	22
100	25	M12	17	M12	56	G1/4"	15	62	82	30	11	10	124	103	103	22

Stelo passante
Through rod

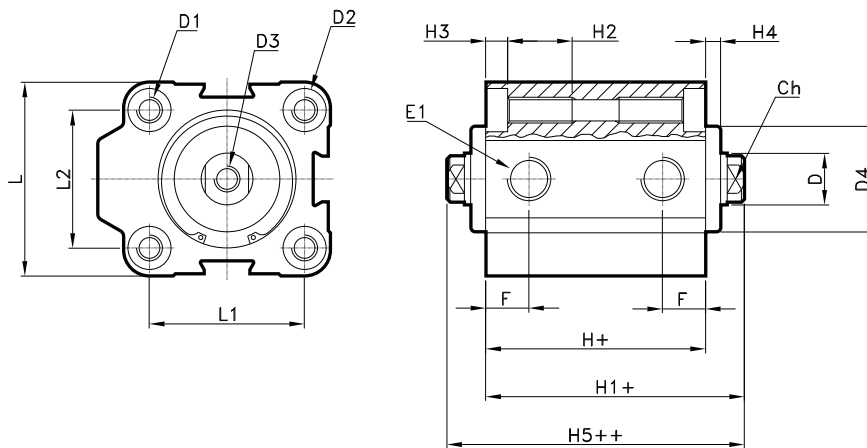
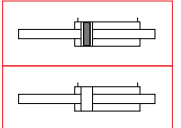

+ = aggiungere la corsa / add the stroke
++ = aggiungere la corsa x 2 / add the stroke x 2

Alesaggio cilindro(mm)	D ø	D1	D2 ø	D3	D4 ø	E1	F	H	H1	H2	H3	H4	H5	L	L1	L2	Ch
16	8	M4	6	M5	-	M5	8	31	35.5	10	3.5	-	40	28	20	20	7
20	10	M5	7	M5	-	M5	8.5	31	35.5	12	4.5	-	40	32	22	22	8
25	10	M5	7	M5	-	G1/8"	9	33	38.5	12	4.5	-	44	38	28	26	8
32	12	M6	10	M6	24.5	G1/8"	10	36	45	15	5.5	3.5	54	45	36	32	10
40	12	M6	10	M6	30	G1/8"	11.5	41	53	15	5.5	5.5	65	54.5	40	40	10
50	16	M8	12	M8	35	G1/8"	11.5	42	55	20	6.5	5.5	68	65	50	50	13
63	16	M10	14	M8	35	G1/8"	12	42	57	25	9	6.5	72	80	62	62	13
80	25	M10	14	M10	44	G1/4"	14	52	70	25	9	10	88	100	82	82	22
100	25	M12	17	M12	56	G1/4"	15	62	82	30	11	10	102	124	103	103	22

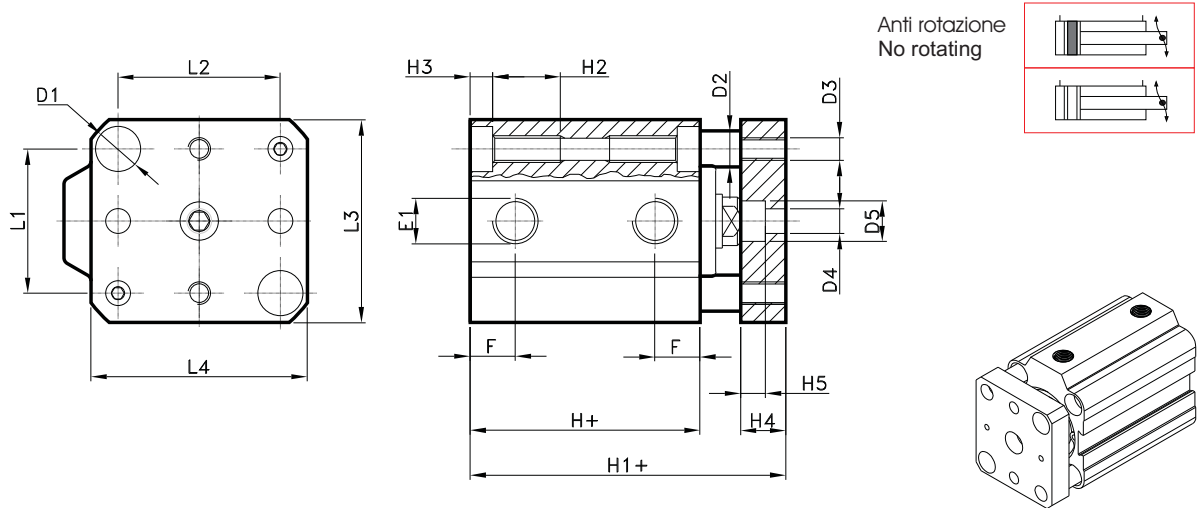

+ = aggiungere la corsa / add the stroke
 ++ = aggiungere la corsa x 2 / add the stroke x 2

Alesaggio cilindro(mm)	D1 ∅	D2 ∅	D3	D4 ∅	D5 ∅	E1	F	H	H1	H2	H3	H4	H5	L1	L2	L3	L4
16	6	4	M3	3.6	6	M5	8	31	43.5	10	3.5	8	3.5	20	20	28	28
20	7	6	M4	4.5	7.5	M5	8.5	31	43.5	12	4.5	8	4.5	22	22	32	32
25	7	6	M4	4.5	7.5	G1/8"	9	33	46.5	12	4.5	8	4.5	26	28	38	39
32	10	8	M5	5.5	9	G1/8"	10	36	55	15	5.5	10	5.5	32	36	45	48
40	10	8	M5	5.5	9	G1/8"	11.5	41	63	15	5.5	10	5.5	40	40	54.5	54.5
50	12	10	M6	7	11	G1/8"	11.5	42	67	20	6.5	12	6.5	50	50	65	65
63	14	10	M6	7	11	G1/8"	12	42	69	25	9	12	6.5	62	62	80	80
80	14	12	M8	8.5	14	G1/4"	14	52	85	25	9	15	8.5	82	82	100	100
100	17	12	M8	8.5	14	G1/4"	15	62	97	30	11	15	8.5	103	103	124	124

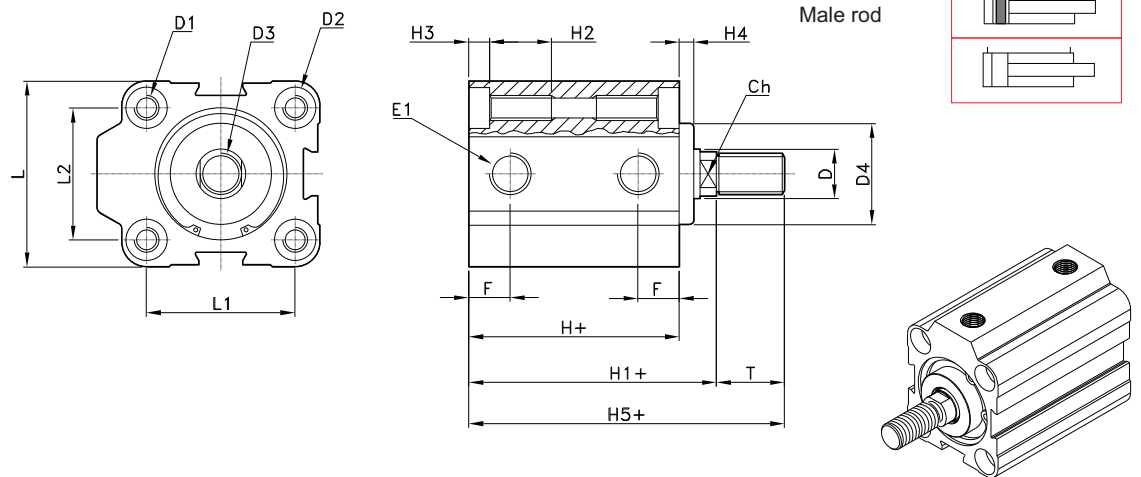

+ = aggiungere la corsa / add the stroke
 ++ = aggiungere la corsa x 2 / add the stroke x 2

Alesaggio cilindro(mm)	D ∅	D1	D2 ∅	D3	D4 ∅	E1	F	H	H1	H2	H3	H4	H5	L	L1	L2	Ch	T
16	8	M4	6	M6	-	M5	8	31	35.5	10	3.5	-	55.5	28	20	20	7	18
20	10	M5	7	M8	-	M5	8.5	31	35.5	12	4.5	-	55.5	32	22	22	8	20
25	10	M5	7	M8	-	G1/8"	9	33	38.5	12	4.5	-	60.5	38	28	26	8	20
32	12	M6	10	M10x1.25	24.5	G1/8"	10	36	45	15	5.5	3.5	67	45	36	32	10	22
40	12	M6	10	M10x1.25	30	G1/8"	11.5	41	53	15	5.5	5.5	77	54.5	40	40	10	22
50	16	M8	12	M12x1.25	35	G1/8"	11.5	42	55	20	6.5	5.5	87	65	50	50	13	24
63	16	M10	14	M12x1.25	35	G1/8"	12	42	57	25	9	6.5	89	80	62	62	13	24
80	25	M10	14	M20x1.5	44	G1/4"	14	52	70	25	9	10	110	100	82	82	22	32
100	25	M12	17	M20x1.5	56	G1/4"	15	62	82	30	11	10	122	124	103	103	22	32

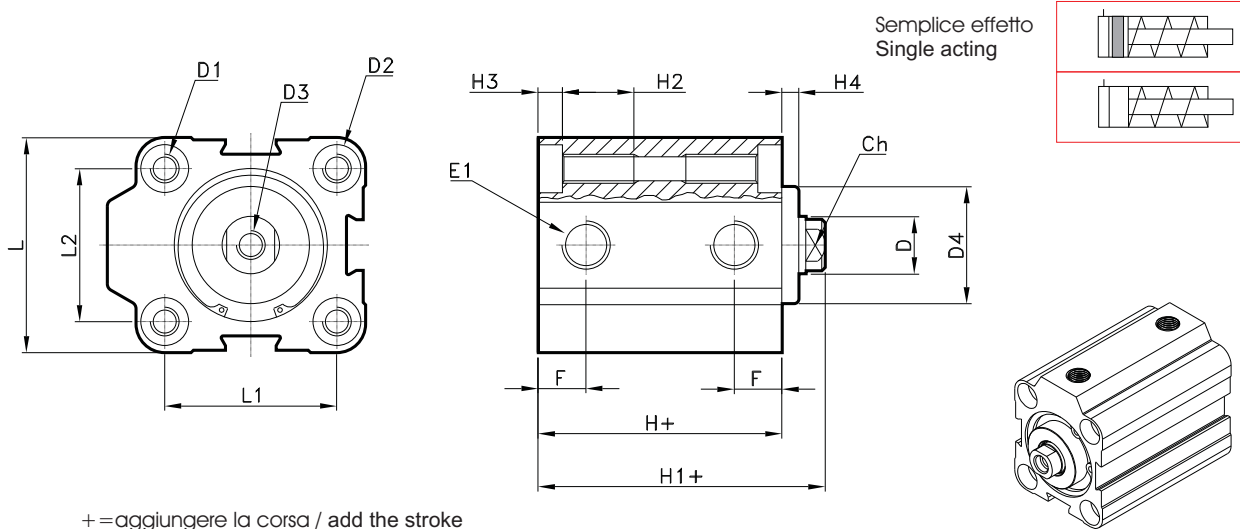

+ = aggiungere la corsa / add the stroke
 ++ = aggiungere la corsa x 2 / add the stroke x 2

Alesaggio cilindro(mm)	D ø	D1	D2 ø	D3	D4 ø	E1	F	H	H1	H2	H3	H4	L	L1	L2	Ch
16	8	M4	6	M5	-	M5	8	31	35.5	10	3.5	-	28	20	20	7
20	10	M5	7	M5	-	M5	8.5	31	35.5	12	4.5	-	32	22	22	8
25	10	M5	7	M5	-	G1/8"	9	33	38.5	12	4.5	-	38	28	26	8
32	12	M6	10	M6	24.5	G1/8"	10	36	45	15	5.5	3.5	45	36	32	10
40	12	M6	10	M6	30	G1/8"	11.5	41	53	15	5.5	5.5	54.5	40	40	10
50	16	M8	12	M8	35	G1/8"	11.5	42	55	20	6.5	5.5	65	50	50	13
63	16	M10	14	M8	35	G1/8"	12	42	57	25	9	6.5	80	62	62	13
80	25	M10	14	M10	44	G1/4"	14	52	70	25	9	10	100	82	82	22
100	25	M12	17	M12	56	G1/4"	15	62	82	30	11	10	124	103	103	22

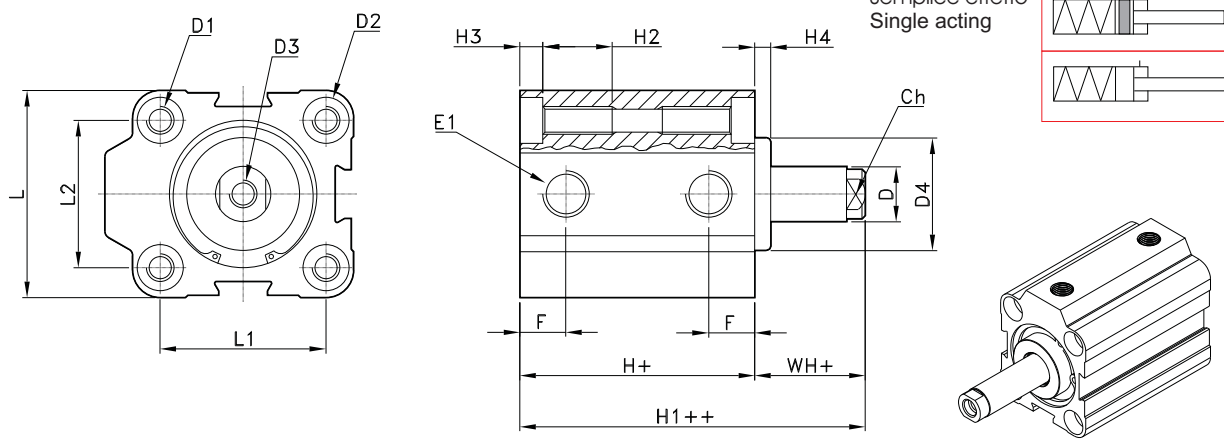

+ = aggiungere la corsa / add the stroke
 ++ = aggiungere la corsa x 2 / add the stroke x 2

Alesaggio cilindro(mm)	D ø	D1	D2 ø	D3	D4 ø	E1	F	H	H1	H2	H3	H4	L	L1	L2	Ch	WH
16	8	M4	6	M5	-	M5	8	31	35.5	10	3.5	-	28	20	20	7	4.5
20	10	M5	7	M5	-	M5	8.5	31	35.5	12	4.5	-	32	22	22	8	4.5
25	10	M5	7	M5	-	G1/8"	9	33	38.5	12	4.5	-	38	28	26	8	5.5
32	12	M6	10	M6	24.5	G1/8"	10	36	45	15	5.5	3.5	45	36	32	10	9
40	12	M6	10	M6	30	G1/8"	11.5	41	53	15	5.5	5.5	54.5	40	40	10	12
50	16	M8	12	M8	35	G1/8"	11.5	42	55	20	6.5	5.5	65	50	50	13	13
63	16	M10	14	M8	35	G1/8"	12	42	57	25	9	6.5	80	62	62	13	15
80	25	M10	14	M10	44	G1/4"	14	52	70	25	9	10	100	82	82	22	18
100	25	M12	17	M12	56	G1/4"	15	62	82	30	11	10	124	103	103	22	20

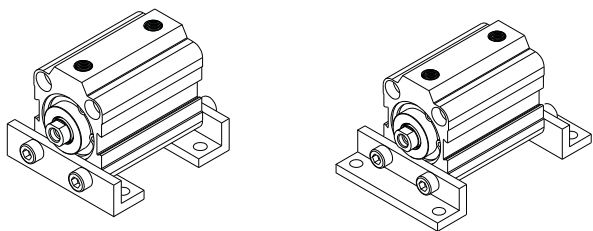

PIEDINO / PEDESTAL

COD.	Ø
AR4201016	16
AR4201020	20
AR4201025	25
AR4201032	32
AR4201040	40
AR4201050	50
AR4201063	63
AR4201080	80
AR4201100	100

Ø	A	B	C	D Ø	D1 Ø	E	F	G	XA	XB	XC
16	48	37	5	6.5	M4	10	8	5	16	46	20.5
20	54	42.5	5	5.5	M5	10	8.5	5	16	46	21.5
25	62	48.5	7.5	5.5	M5	12.5	9	5	17.5	57.5	27.5
32	70	57	7.5	6.5	M6	12.5	20	5	21	61	31
40	80	66.5	7.5	6.5	M6	12.5	11.5	5	23	63	34.3
50	100	80	10	8.5	M8	15	11.5	5	22	72	42.5
63	118	98	10	10.5	M10	15	12	5	24	74	47.5
80	141	118	15	10.5	M10	20	14	5	20	90	60
100	169	144	15	13	M12	20	15	5	27	97	72

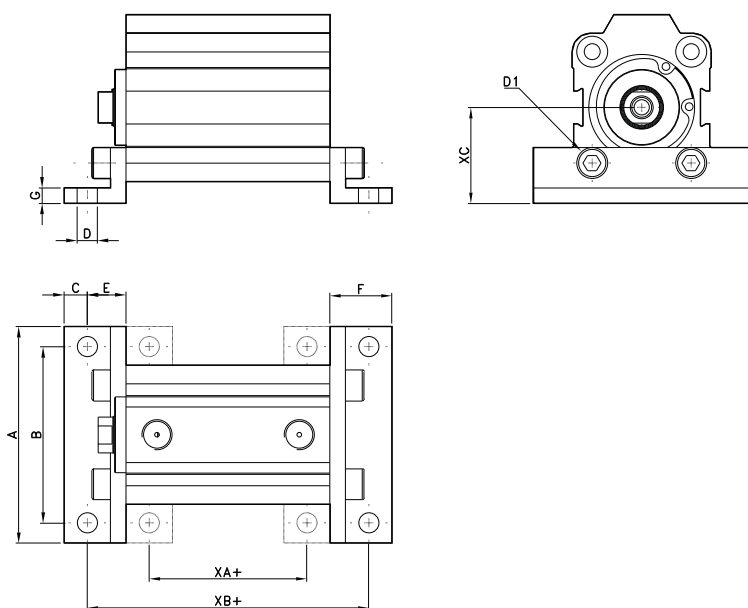

Materiale: Acciaio
Material: Steel



ADATTATORE PER STELO MASCHIO /
ADAPTOR FOR MALE ROD

COD.	Ø
AR402820	20
AR402825	25
AR402832	32
AR402840	40
AR402850	50
AR402863	63

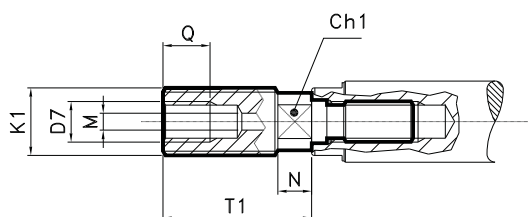

Ø	D7	M	T1	Q	N	Ch1	K1
20	M5	2	22	10	5	7	M10x1.25
25	M5	2	22	10	5	7	M10x1.25
32	M6	2	22	10	5	7	M10x1.25
40	M6	2	22	10	5	7	M10x1.25
50	M8	3.5	24	12	5	9	M12x1.25
63	M8	3.5	24	12	5	9	M12x1.25

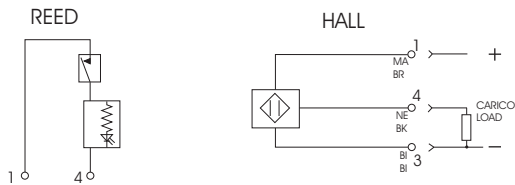
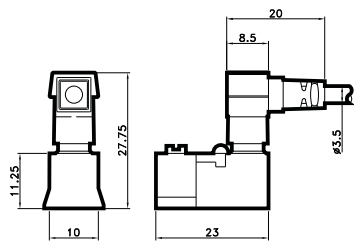

SENSORE MAGNETICO
MAGNETIC SWITCH
COD.

AR4025110	REED 2 FILI (MT.2,5) / REED WITH 2 WIRES (MT.2,5)
AR4025120	HALL 3 FILI (MT.2,5) / HALL WITH 3 WIRES (MT.2,5)

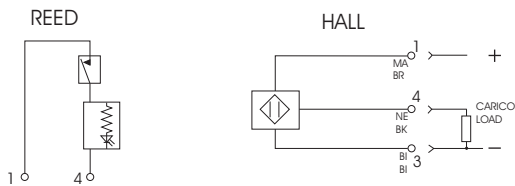
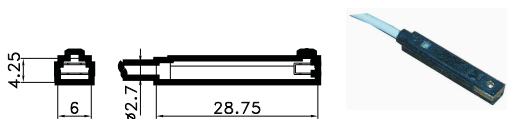

SENSORE A T
"T" SWITCH
COD.

AR4023010	REED 2 FILI (MT.2,5) / REED WITH 2 WIRES (MT.2,5)
AR4023020	HALL 3 FILI (MT.2,5) / HALL WITH 3 WIRES (MT.2,5)
AR4023110	REED 2 FILI + M8 (CM 30) / REED WITH 2 WIRES WITH M8
AR4023120	HALL 3 FILI + M8 (CM 30) / HALL WITH 3 WIRES WITH M8

DATI TECNICI / TECHNICAL DATA

Grado di protezione / Protection class	IP 67 EN 60529
Temp. di impiego / Working temp.	-20C° +85C°
Materiale custodia / Housing material	PA
Tensione in DC / Tension in DC	Reed 3-30V / Hall 6-30V
Tensione in AC / Tension in AC	Reed 3-30V
Corrente a 25 C° / Corrent at 25 C°	Reed 0,20A / Hall 0,20A
Tempo inserzione / On time	Reed 0,5mS / Hall 0,8 uS
Tempo disinserzione / Off time	Reed 0,1 mS / Hall 0,3 uS

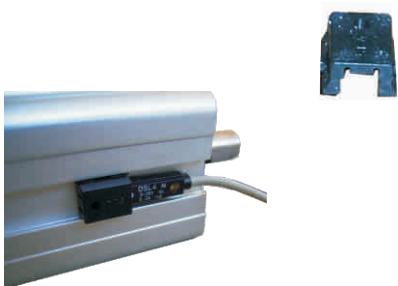

ADATTATORE PER SENSORE A T
ADAPTOR FOR T SWITCH
COD.
AR40060

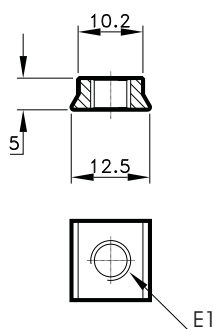

PIASTRINE PER FISSAGGIO A PARETE / FIXING NUT
COD.

AR4231032	16-32
AR4231100	32-100

Ø	E1
16-32	M5
32-100	M6